

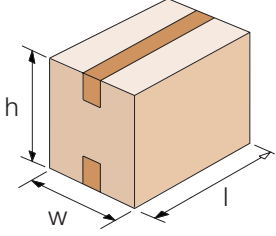

- Paslanmaz çelik gövde ve aksamlar
- **PLC** kontrol sistemi (**OMRON**)
- 7" renkli **LCD Türkçe** operatör paneli (**OMRON**)
- Zaman ve hız ayarları operatör paneli üzerinden
- Otomatik alt kapak kapatma sistemi
- Pnömatik silindir tahrikli koli açma ve itme sistemi (**FESTO**)
- Mekanik güvenlik anahtarlı güvenlik kapıları (**SICK**)
- Kapılar açıldığında otomatik durma
- Koli magazin haznesi (100 koli kapasiteli)
- Manüel koli ölçü ayarı
- Kolay ulaşılabilir Acil Stop butonları
- Kolay ve hızlı ölçü ayar değişimi
- Yağlama gerektirmeyen pnömatik sistem (**FESTO**)
- Yandan kayış sürüklemeli, çift motorlu koli taşıma (**SEW**)
- TBD-50 bantlama dispenseri (Max. 50mm bant genişliği)
- Alttan koli bantlama (TBD-50)
- Uluslararası standartlara uygun tüm koli ve koli bandı çeşitleri ile çalışma
- Avrupa standartlarında Bant Dispanseri ve Koli Taşıma Sistemi
- Minimum bakım gereksinimi
- **CE sertifikalı**
- Stainless Steel body and parts
- **PLC** control system (**OMRON**)
- 7" coloured **LCD** operator panel (**OMRON**)
- Timing and speed adjustment on operator panel
- Automatic four-flaps-folder system for bottom flaps
- Pneumatic cylinder driven box opening and pushing system (**FESTO**)
- Safety doors with mechanical safety switches (**SICK**)
- Automatic stop when doors are opened
- Box storage for 100 boxes
- Manual dimension adjustment
- Emergency Stop buttons
- Easy and fast size setting
- Pneumatic system that does not require lubrication (**FESTO**)
- Two motorized side drive belts (**SEW**)
- TBD-50 taping dispenser (Max. 50mm tape width)
- Bottom sealing (TBD-50)
- Working with all case and tape types in accordance with international standards
- Tape dispenser and case transport system in European standards
- Minimum maintenance requirement
- **CE certificated**

### Koli Ölçüleri Case Dimensions



	L (mm)	W (mm)	H (mm)
Min.	150	130/150*	120/100**
Max.	620	420	500

\* TBD-75 Bantlama Dispanseri İle  
\* With TBD-75 Taping Dispenser  
\*\* Koli Geniřlięi Min. 200mm  
\*\* Case Width Min. 200mm

### Bantlama Dispanseri Taping Dispenser

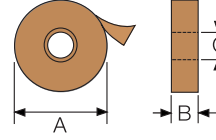

	TBD-50	TBD-75
A	Max. 400 mm	
B	50 mm	75 mm
C	76 mm	

\*\*\*Farklı Ebatlar İin Bizimle İrtibata Geiniz  
\*\*\*For Different Case Size Please Contact Us

### Elektrik Baęlantı Electrical Connection

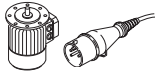

380V - 50Hz- 3 Ph
1,5 A
0,24 Kw
3Ph + PE + N

### Kapasite Capacity

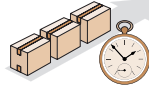

TKH-40
Max. 12 Koli/Dakika - Cases/Minute

### Hava Baęlantı Air Connction

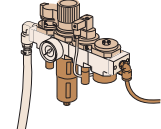

5-7 Bar
0.5 Lt
Ø10 mm

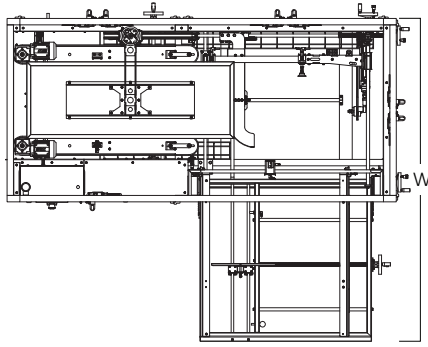

TKH-40-L

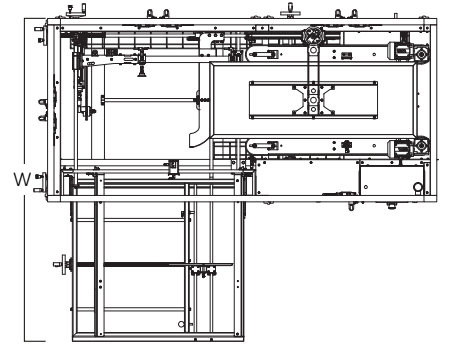
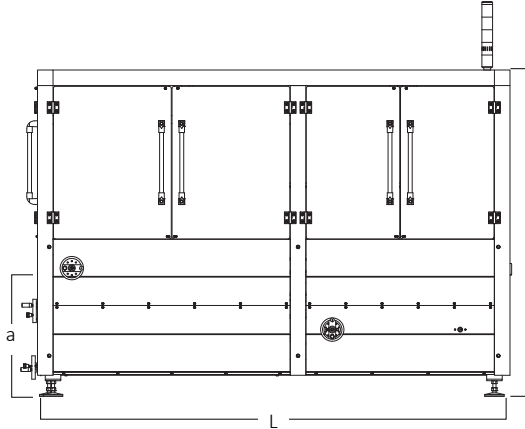



TKH-40-R



### Makine Ölüleri Machine Dimensions

	TKH-40			
(mm)	L	W	H	a
Min.	2.430	1.990	1.680	600
Max.	-	-	1.730	650

### Aęırlık - Paket Ölüleri Weight - Packaging Size

			
TKH-40	650	750	250x140x180



### Opsiyonlar Options

Frenli Tekerlek  
Casters With Brake

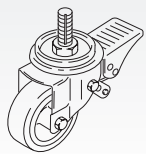

TBD-75 Dispanser  
TBD-75 Dispenser

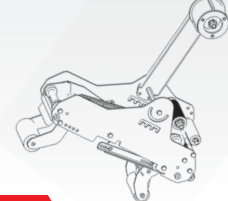

Rulolu Konveyörler  
Roller Conveyors

