

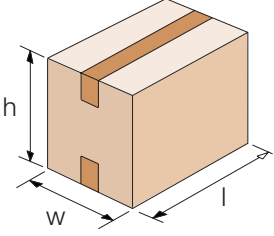

- Paslanmaz çelik gövde ve aksamlar
- PLC kontrol sistemi (**SIEMENS**)
- 7" renkli **LCD** Türkçe operatör paneli (**SIEMENS**)
- Zaman ve hız ayarları operatör paneli üzerinden
- Ürüne göre reçete oluşturma ve kaydetme seçeneği
- Otomatik alt kapak kapatma sistemi
- Servo motor tahrikli koli açma ve itme sistemi
- Mekanik güvenlik anahtarlı güvenlik kapıları (**SICK**)
- Kapılar açıldığında otomatik durma
- Koli magazin haznesi (100 koli kapasiteli)
- Manüel koli ölçü ayarı
- Kolay ulaşılabilir Acil Stop butonları
- Kolay ve hızlı ölçü ayar değişimi
- Yağlama gerektirmeyen pnömatik sistem (**FESTO**)
- Yandan kayış sürüklemeli, çift motorlu koli taşıma (**SEW**)
- TBD-50 bantlama dispanseri (Max. 50mm bant genişliği)
- Alttan koli bantlama (TBD-50)
- Uluslararası standartlara uygun tüm koli ve koli bandı çeşitleri ile çalışma
- Avrupa standartlarında Bant Dispanseri ve Koli Taşıma Sistemi
- Minimum bakım gereksinimi
- **CE sertifikalı**

- **Stainless Steel body and parts**
- **PLC control system (SIEMENS)**
- **7" coloured LCD operator panel (SIEMENS)**
- Timing and speed adjustment on operator panel
- Storing of working programs for different case dimensions
- Automatic four-flaps-folder system for bottom flaps
- Servo motor driven box opening and pushing system
- Safety doors with mechanical safety switches (**SICK**)
- Automatic stop when doors are opened
- Box storage for 100 boxes
- Manual dimension adjustment
- Emergency Stop buttons
- Easy and fast size setting
- Pneumatic system that does not require lubrication (**FESTO**)
- Two motorized side drive belts (**SEW**)
- TBD-50 taping dispenser (Max. 50mm tape width)
- Bottom sealing (TBD-50)
- Working with all case and tape types in accordance with international standards
- Tape dispenser and case transport system in European standards
- Minimum maintenance requirement
- **CE certificated**

### Koli Ölçüleri Case Dimensions



	L (mm)	W (mm)	H (mm)
Min.	150	130/150*	120/100**
Max.	620	420	500

\* TBD-75 Bantlama Dispanseri İle  
\* With TBD-75 Taping Dispenser  
\*\* Koli Geniřlięi Min. 200mm  
\*\* Case Width Min. 200mm

### Bantlama Dispanseri Taping Dispenser

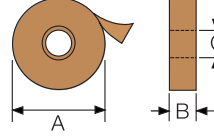

	TBD-50	TBD-75
A	Max. 400 mm	
B	50 mm	75 mm
C	76 mm	

\*\*\*Farklı Ebatlar İçin Bizimle İrtibata Geçiniz  
\*\*\*For Different Case Size Please Contact Us

### Elektrik Bağlantı Electrical Connection

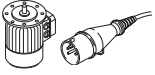

380V - 50Hz- 3 Ph
6A
1,4 Kw
3Ph + PE + N

### Kapasite Capacity

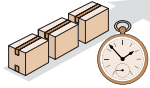

TKH-45
Max. 18 Koli/Dakika - Cases/Minute

### Hava Bağlantı Air Connction

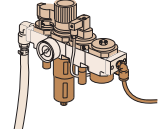

5-7 Bar
0.3 Lt
Ø10 mm

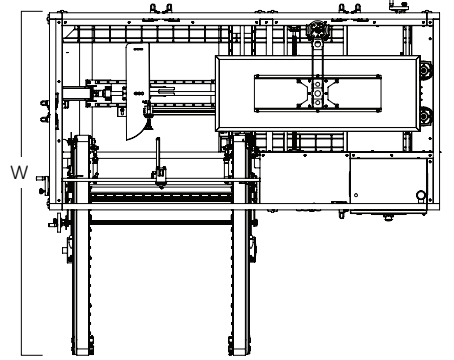
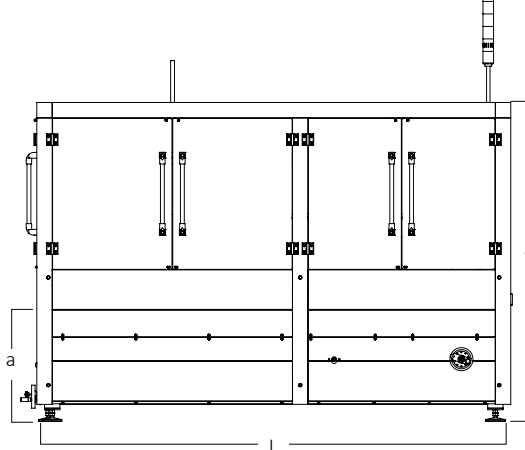
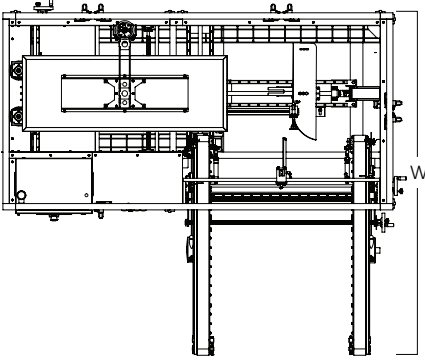

TKH-45-L

### Makine Ölçüleri Machine Dimensions

	TKH-45			
(mm)	L	W	H	a
Min.	2.465	2.160	1.680	600
Max.	-	-	1.730	650

### Ağırlık - Paket Ölçüleri Weight - Packaging Size

	KG	KG	LxWxH (cm)
TKH-45	650	750	250x230x180



TKH-45-R

### Opsiyonlar Options

Frenli Tekerlek  
Casters With Brake

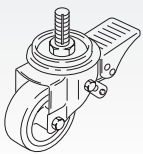

TBD-75 Dispanser  
TBD-75 Dispenser

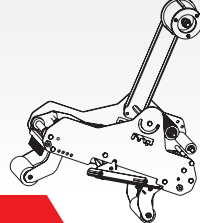

Rulolu Konveyörler  
Roller Conveyors

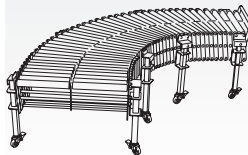

Otomatik Ölçü Ayarı  
Automatic Dimensions  
Adjustment

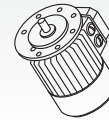

Sıcak Tutkal Sistemi  
Hot-Melt Glue System

